

Installation manual for round ducts and fittings

This installation manual is designated for round ducts and fittings manufactured by Leovira UAB. Products comply with standard EN 1506:2007. Detailed information is given in the item descriptions of each type of product or by consulting with Leovira UAB team.

Installation shall be performed in accordance with working safety requirements, using appropriate safety equipment and carried out by qualified specialists.



Before starting the installation of the system, it should be made sure, that the available equipment and products are properly prepared, clean, have no defects and comply with criteria specified in the project.

- Interconnection of system components:
 - With fittings that include a rubber sealing gasket – couplings, elbows, reducers, etc. Rubber is coated with a material that aids slipping in when installing. If needed, special lubricant could be used. Fitting should be inserted into the duct up to its support edge. Connection is fastened with self-tapping screws or rivets.

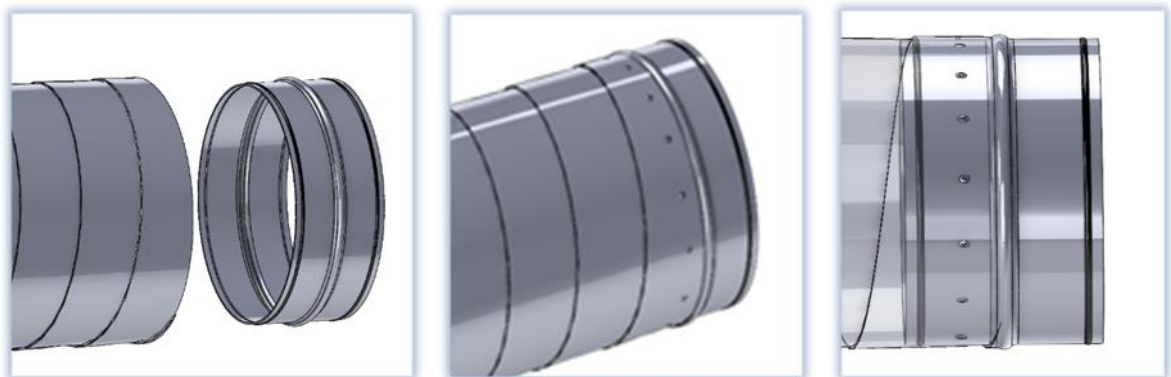

- Interconnection of ducts with widened ends by inserting one into another (OSP, OTP). When using this type of connection, special sealant is needed, because there is no rubber gasket. Fastening with self-tapping screws or rivets.

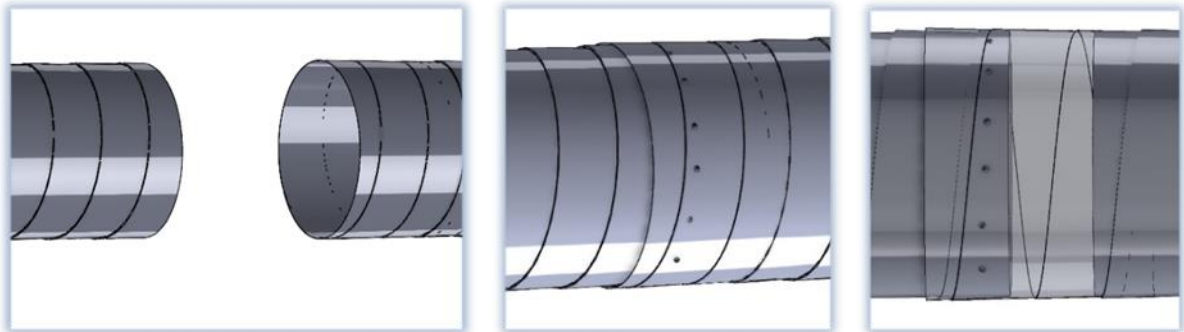

- Connection of ducts with external couplings (LMF). When using this type of connection, special sealant is needed, because there is no rubber gasket. Fastening with self-tapping screws or rivets.

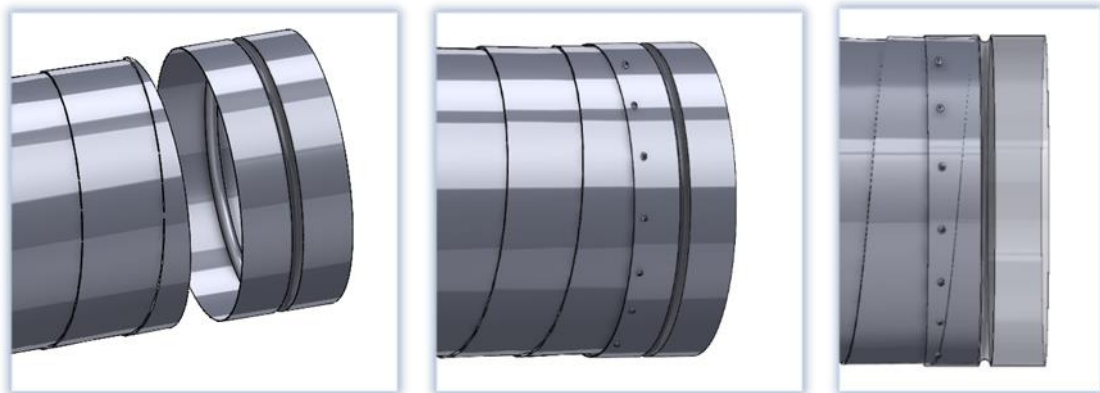

- Flanged connections (for ducts OTF), by applying a layer of sealing material (e.g., PVC stripe) to the brim of the flanges and tightening them with bolts.

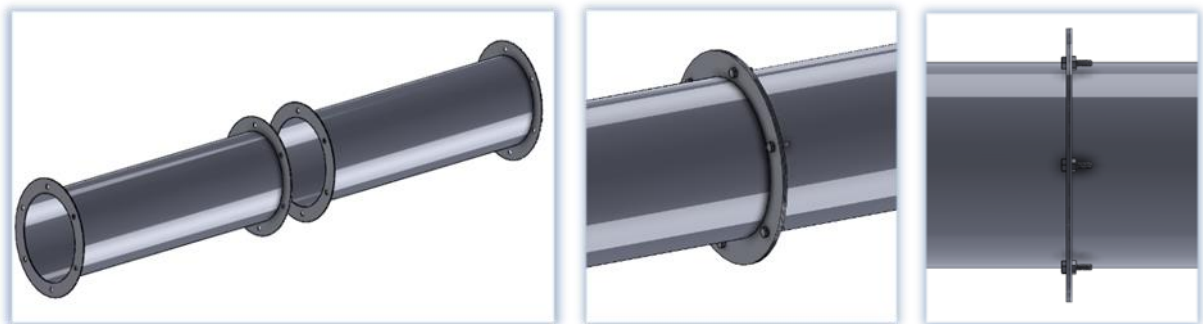

The fastening elements, used for connection of parts, (screws, rivets) should be spread out evenly around the perimeter. To achieve better tightness, it is recommended to use special sealant or silicone for

ventilation. Ducts can be shortened to required length by cutting perpendicular to longitudinal axis. After cutting, it is needed to make sure, that there are no sharp edges which could damage the sealing gasket or cause injuries while working.

- Interconnection of fittings:
 - Connection with external couplings (LMF) – fitting should be inserted into the coupling up to its support edge and fastened with self-tapping screws or rivets.

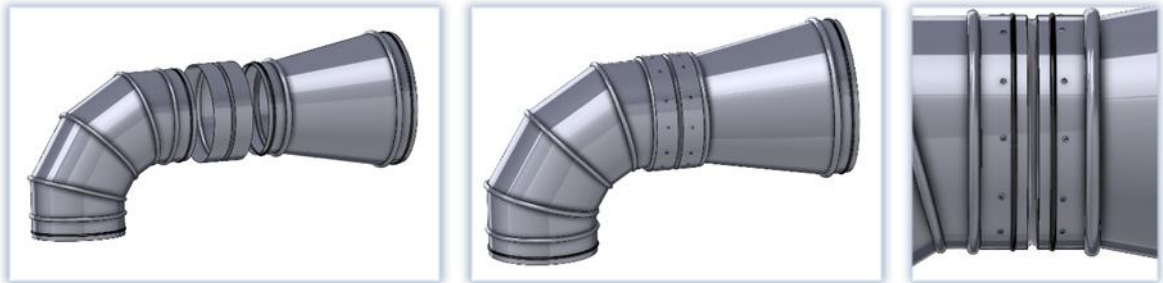

- Connection with a duct or a sleeve of sheet metal which has a minimal length not less than it is needed to cover both necks of the fittings up to their support edges. Fastened with self-tapping screws or rivets.

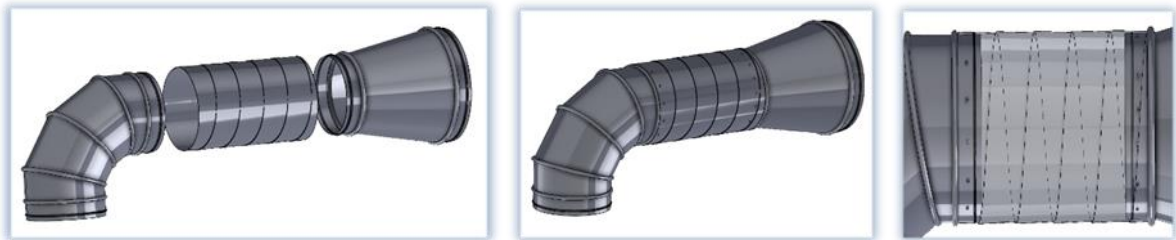

- Hanging of a duct system:
 - With clamps (OPL, OPV, OPP, OPS) – according to the diameter of the duct. It is recommended to install clamps at intervals of 2 meters for straight duct sections and at most 500 mm from connections of fittings.

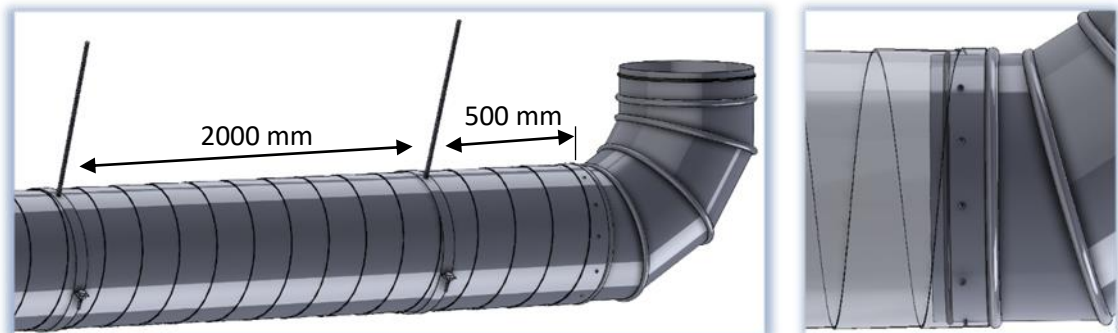

Clamps are secured to the structure of a building by threaded rods. Strength of the fastening elements should be selected by taking into consideration the weight of all the parts of the system (with additional materials, e.g., insulation) and a safety coefficient of 1.5 (according to standard EN 12236:2002).

- Perforated band or a special cable with retainers.

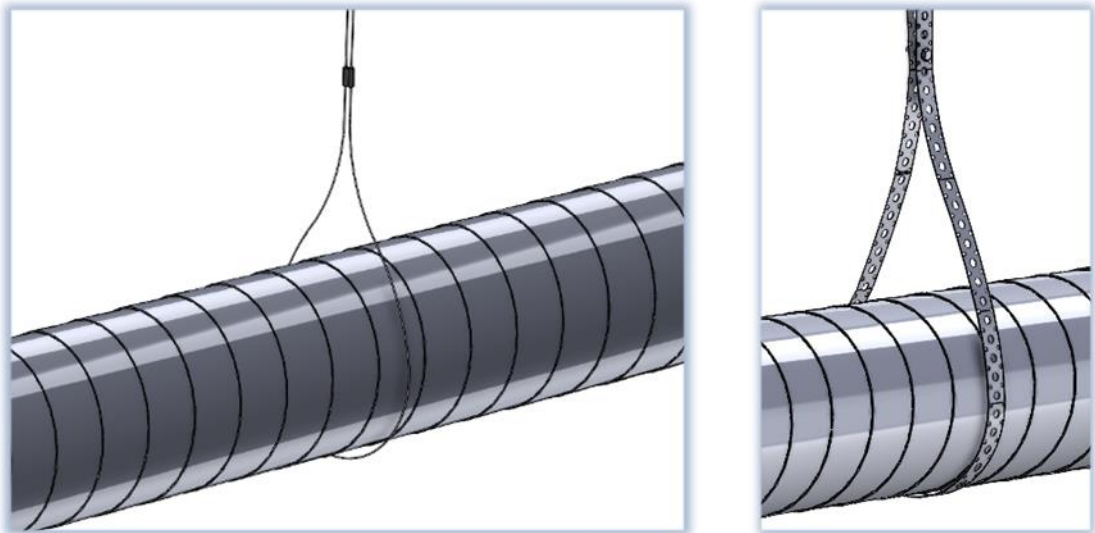

To minimise vibrations, Z, L, R-T types of hangers with a rubber bushing can be used. These hangers can serve as an intermediate component on the support brackets or can be fastened directly to the structure of the building.

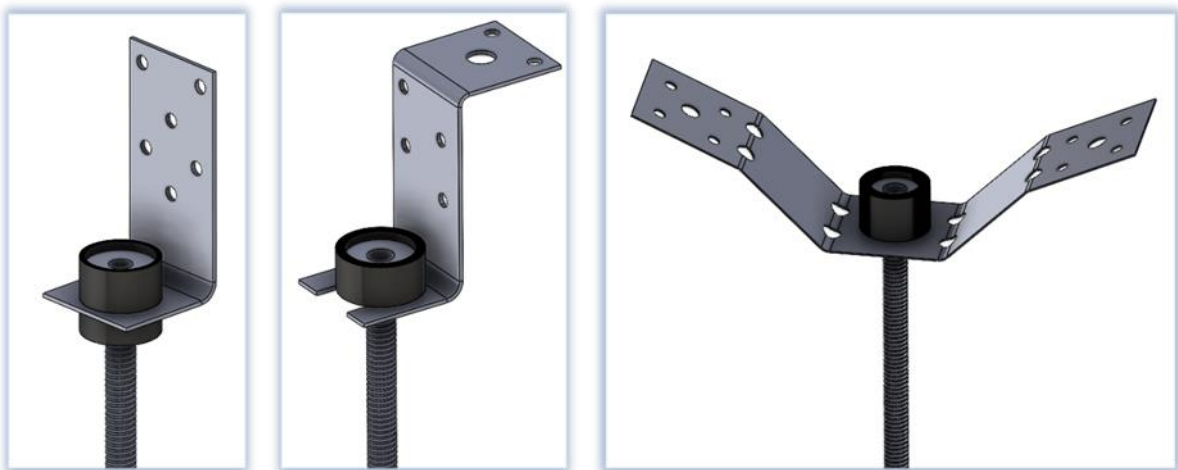

- Maintenance of the duct system:

System should be appropriately maintained and cleaned periodically. Inspection hatches are installed at places where the duct line is changing in its cross-section, branching, turning (more than 45°) and at straight sections – at every 7,5 meters (according to standard EN 12097:2006).

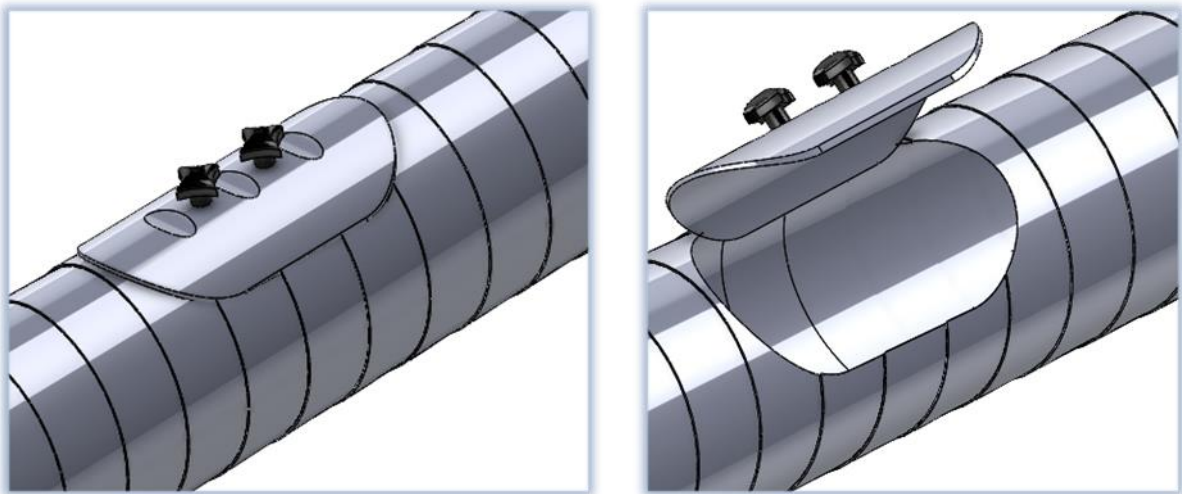

Taking into account external factors, if ducts are wanted to be protected against condensation, corrosion and other external damage, it is recommended to use external insulation, various protective coatings. If at the time of inspecting the working order of the system a spot of corrosion is noticed, it should be coated with zinc spray paint. Also grounding (earthing) of the system is important to prevent static charges from forming and decrease the danger in case of an electrical discharge (e.g., a failure of ventilator or other equipment, that has a contact with the system).

- Silencers:

Round silencers can be installed in any airflow direction, except **TST** silencers with centre splitter. TST silencers must be installed in the correct direction of airflow as indicated on the sticker.

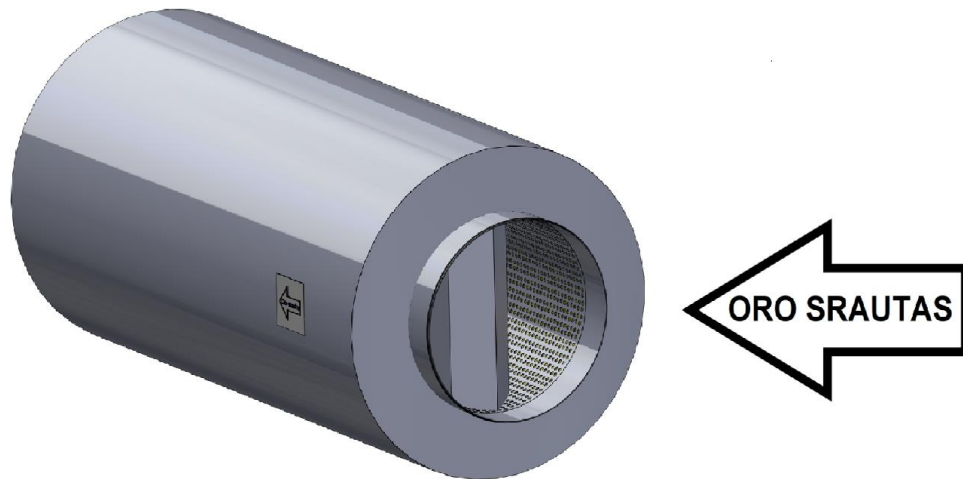

In case the silencer is being installed close to the inlet/outlet, ensure no precipitation gets inside. If the noise dampening material gets wet, the silencer will no longer perform its function.



- Multi-blade dampers:

Dampers are connected in the same manner as other ventilation system components. When mounting very close to a wall or ceiling, a duct branch should be installed in the opening and must protrude at least 30mm above the surface of the wall or ceiling before a multi-blade damper can be connected.

Important:

- During installation, ensure that the geometry of the body is not damaged or distorted. After installation, use an angle measuring tool to verify that the angles of the valve are exactly 90 degrees;
- Installed in both horizontal and vertical systems;
- In a horizontal system, install the damper so that the blades are positioned horizontally to prevent jamming;
- Air flow direction is possible in both directions;
- During operation, the damper blades must not be accessible. Ensure a safety net or grille is installed to prevent access;
- After installation, verify that the damper operates smoothly. Check that the blades rotate synchronously and do not come into contact with the body or any other elements of the system;
- If the connection edge (A or B) of the damper is 1 meter or longer, it must be additionally supported from below or suspended to ensure stability.

Maintenance:

It is recommended to conduct inspections of multi-blade dampers concurrently with the overall ventilation system inspections, or at least every six months.

Visual inspection:

- Inspect the damper's body for external damage and any other obstacles that could obstruct the free movement of the blades;
- Turn the handle in both directions (to close and to open) to ensure that the blades fully open and close;
- Check that the sealing gaskets on the edges of the blades are properly positioned and securely attached along their entire length;
- If the damper is equipped with an actuator, check whether it is securely attached and not loose, and ensure that the blades are moving smoothly.

Periodic Service:

- Perform cleaning concurrently with the cleaning of the entire ventilation system to ensure consistency and efficiency;
- Avoid the use of solvents, such as acetone, that can dissolve plastic parts.;
- After cleaning, thoroughly inspect plastic bushings and sealing gaskets for any signs of damage. Ensure they are intact and properly positioned to maintain system integrity and performance.