

Lesstro Standard R500VE-DE RV022E

AHU with rotary heat exchanger

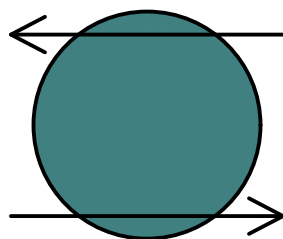

A - outdoor intake air
 B - supply air
 C - extract indoor air
 D - exhaust air

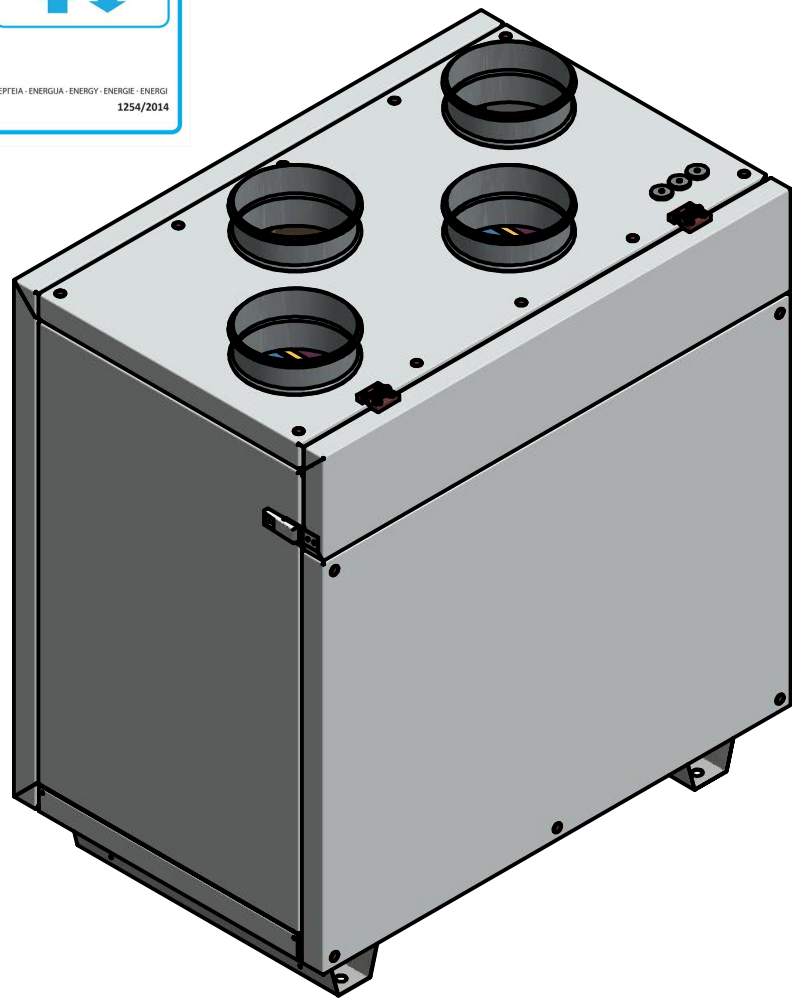
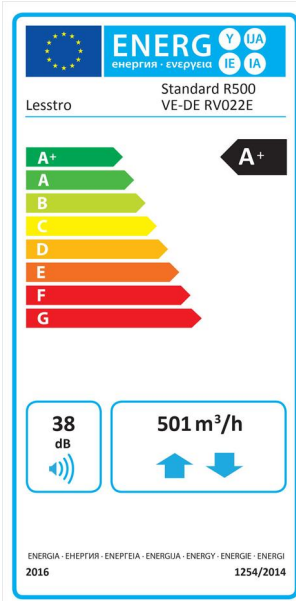
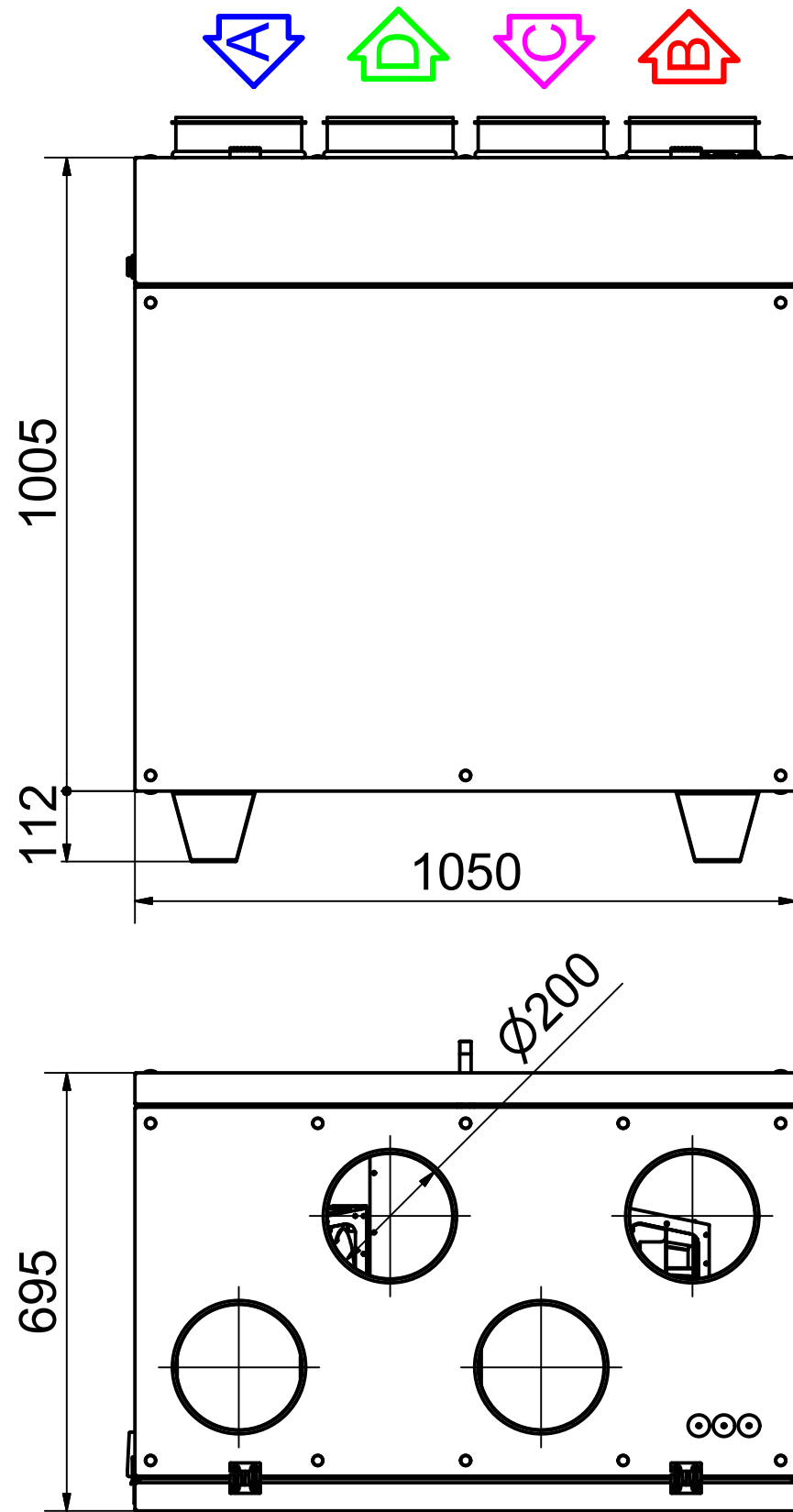

SPECIFICATION

Energy efficiency class:	A+
Nominal air flow, m ³ /h:	500
Supply voltage, V:	230
EC fans, 2x kW:	0.170
Electrical heater, kW:	1.0
Maximal operating current, A:	8
Panel thickness, mm:	50
Weight, kg:	120
Operation:	indoor
Sound level, dB(A):	38
Filter dimensions, mm:	580x220x46
Control panel:	PT1-B1
Color code:	RAL9010



PERFORMANCE

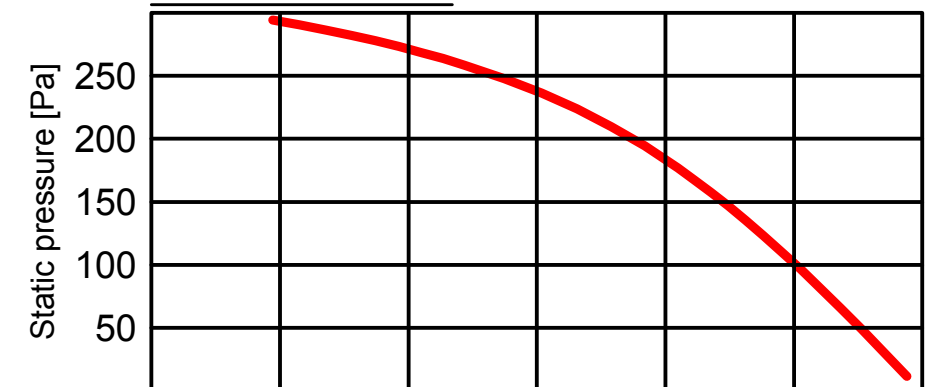

TEMPERATURE EFFICIENCY

